



# Operating Instructions Models 46453 and 464530 Hydrostatic Test Pumps **Specifications**



<b>46453 DIMENSIONS:</b>	27" (67.5cm) L x 22" (55cm) W x 34" (85cm) H
WEIGHT:	160 lbs. 73 kg
PUMP:	Twin piston: Positive displacement type Inlet and Outlet Ports: ¾" NPT Capacity: 10gpm, 38 ltr/Min Pressure: 0-400psi (27 bar) Operating Speed: 600rpm Shaft Size: 1" diameter Lubrication: Chassis grease
ENGINE:	6.5hp Briggs & Stratton Intek Pro, 4 cycle, gasoline powered, with 6-1 gear reduction
CONTROL:	Adjustable pressure relief valve
GAUGE:	Glycerin filled, 0-600psi (41 bar)
DISCHARGE HOSE:	¾" x 10' (3m), rated 1000psi (68 bar) working pressure
INTAKE HOSE:	¾" x 10' (3m) with strainer
<b>464530 DIMENSIONS:</b>	27" (67.5cm) L x 22" (55cm) W x 34" (85cm) H
WEIGHT:	160 lbs. 73 kg
PUMP:	Twin piston: Positive displacement type Inlet and Outlet Ports: ¾" NPT Capacity: 10gpm, 38 ltr/Min Pressure: 0-400psi (27 bar) Operating Speed: 600rpm Shaft Size: 1" diameter Lubrication: Chassis grease
ENGINE: 464530	5.5 hp Honda 4 cycle, gasoline powered, with 6-1 gear reduction
CONTROL:	Adjustable pressure relief valve
GAUGE:	Glycerin filled, 0-600psi (41 bar)
DISCHARGE HOSE:	¾" x 10' (3m), rated 1000psi (68 bar) working pressure
INTAKE HOSE:	¾" x 10' (3m) with strainer



# Operating Instructions Models 46453 and 464530 Hydrostatic Test Pumps

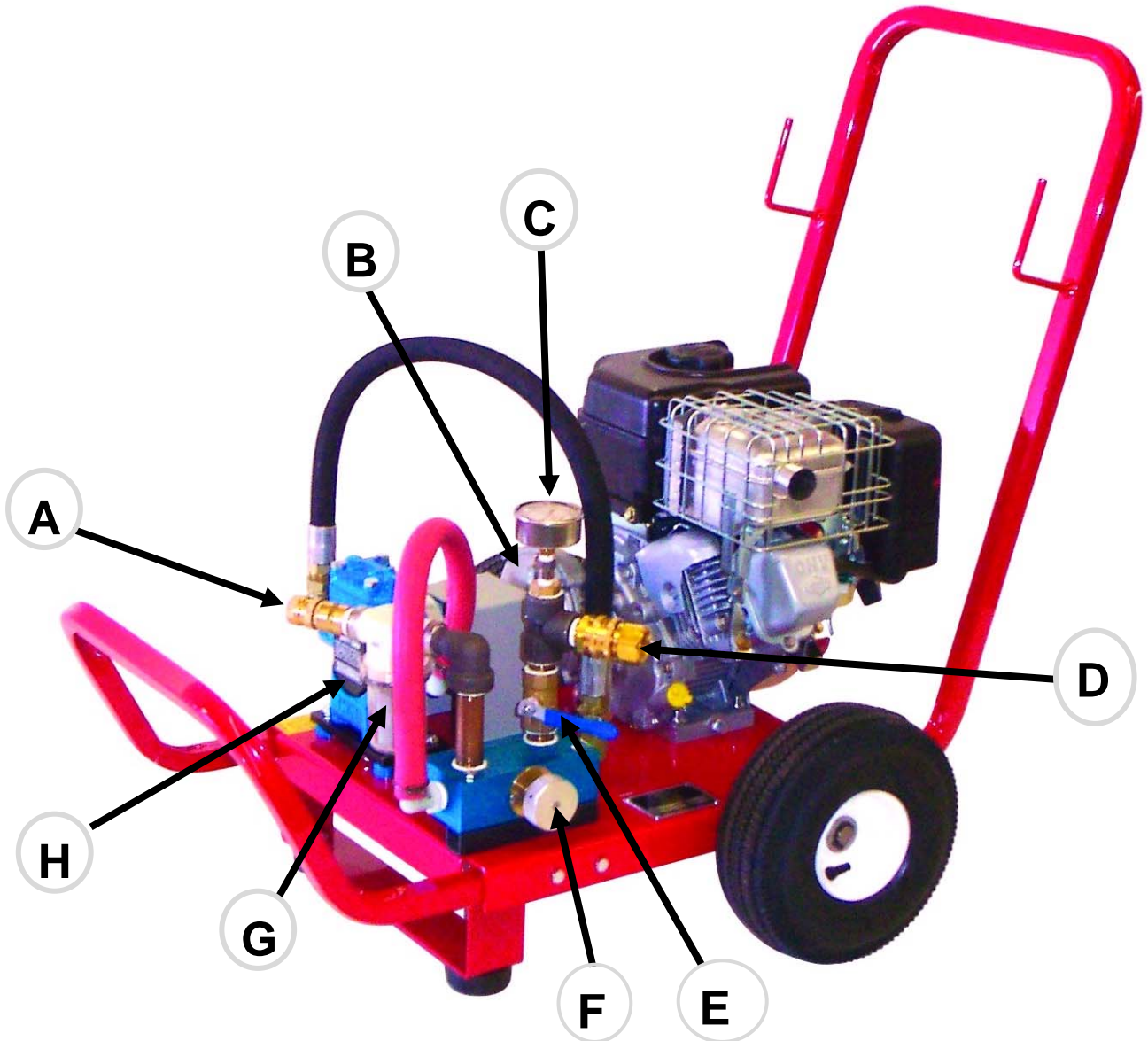

A	Inlet Connection
B	Gear Reduction
C	Gauge
D	Output Connection
E	Isolation Valve
F	Pressure Relief Valve
G	Strainer
H	Pump Cap



# Operating Instructions Models 46453 and 464530 Hydrostatic Test Pumps

## Pressure Feed (or Gravity Feed) Method: (Preferred Methods)

1. Fill the water line (or test vessel) to be tested prior to pump connection.
2. Connect water supply hose to the garden hose inlet connection (A) on the pump.
3. Open valve and turn water supply on.
4. Purge the pump and pressure hose of all air.
5. Connect output (pressure) hose between pump output connection (D) and water line (or vessel) being tested.
6. Turn pump on.
7. Purge water line (or vessel) of all air at the highest point of the system.
8. Bring water line (or vessel) to pressure. Watch the gauge (C) while pumping. When the desired pressure is achieved, turn the isolation valve (E) to the "off" position. The engine can now be turned off. If pressure drops, there is a leak in the line.



## Siphon Method

*Use a clean water source*

1. Fill the water line to be tested.
2. Fill the intake hose (WR PN #34550 - not supplied with pump), with water, then quickly place the hose into a bucket and turn pump on. (The unit is self-priming once primed.) Continue to pump until you see the water coming out of the outlet, with little or no air mixed with it.
3. Connect the output hose to the water line. Continue on with steps 6 through 8 in pressure feed method.

## Pre-Setting Your Pump

*Your pump can be pre-set to a specific pressure easily by adjusting the pressure relief valve.*

1. Unscrew (counterclockwise direction) pressure relief valve knob (F) until it stops. Your pump will now be at 0 (zero) psi.
2. Add a ball valve (not supplied with pump) to the end of the high pressure hose.
3. Follow steps 2 through 4 from the 'Pressure Feed Method'.
4. As water is flowing out of the high pressure hose, turn the ball valve to the off position.
5. Slowly start turning pressure relief valve knob (F) (in the clockwise direction) by  $\frac{1}{4}$  turn increments, until you reach the desired pressure. When the knob is turned in all the way, the maximum pressure is achieved (400psi).
6. Your test pump is now pre-set. This eliminates over-pressurizing the water line (or the vessel).



# Operating Instructions Models 46453 and 464530 Hydrostatic Test Pumps

## Troubleshooting Your Pump

Test pressure not being reached:

- Possible air in line (or vessel)
  - ◊ Air needs to be purged from system.
  - ◊ Remove pump from system and follow steps 1 thru 6 of the "Pre-Setting Your Pump" section.
  - ◊ If using the Siphon Method and not getting pressure, try the 'Pressure Feed' or 'Gravity Feed Method' to ensure water is getting into the pump.
  - ◊ Check strainer (G) O-Ring for cracks.
  - ◊ Check inlet quick disconnect (A) O-Ring for cracks
- Pressure relief valve not adjusted properly.
  - ◊ Turn relief valve counterclockwise and watch for change in pressure.

## Pump Maintenance

- Pump 50/50 antifreeze/water solution through pump after each use to lubricate internal parts of pump and to avoid freezing in cold weather.
- Check strainer O-Ring (G) for cracks prior to each use.
- Check and change engine oil per manufacturer's specs.
- Lube Hypro pump with Moly-Lithium grease. Remove pump cover (H).
- Gear reduction oil - change per engine manual specifications.
- Pump seal kit Wheeler Rex PN 36351
- Suction Hose Wheeler Rex PN 34550

### **CAUTION !!!**

**This pump is designed for water only!!**

The pump is equipped with an adjustable pressure relief valve (F), which helps protect the system from being over pressurized. It can be preset by plugging the end of the hose. Turn the adjusting knob clockwise to increase pressure and counterclockwise to decrease.



## WHEELER-REX LIMITED LIFETIME WARRANTY

WHEELER-REX covers its products with a Limited Lifetime Warranty, with exception of pipe threading machines which have a Limited Three Year Warranty (including electric motors). Warranties from manufacturers of components used in our products may pre-empt the Wheeler-Rex warranty. Wheeler-Rex warranties against defects in material or workmanship. To take advantage of this warranty, the complete product must be delivered prepaid to Wheeler-Rex or any WHEELER-REX AUTHORIZED SERVICE CENTER. No tools are to be returned to the factory without receiving prior authorization. Obviously, failures due to misuse, abuse, or normal wear and tear are not covered by this warranty. **NO OTHER WARRANTY, WRITTEN, OR ORAL, APPLIES. THERE ARE NO WARRANTIES WHICH EXTEND BEYOND THE DESCRIPTION ON THE FACE HEREOF.** No employee, agent, dealer, or other person is authorized to give any warranty on behalf of Wheeler-Rex. Warranted products will be repaired or replaced at our option, at no charge and returned to you via prepaid transportation. Such replacement or repair is the exclusive remedy available from Wheeler-Rex. Wheeler-Rex is not liable for damage of any sort, including incidental and consequential damages. Some U.S.A. states do not allow the exclusion or limitation of incidental or consequential damages, so the above limitation or exclusion may not apply. This warranty gives you specific legal rights, and you may also have other rights which vary from state to state.

Form # 1031

## WARNING

### GENERAL TOOL OPERATION WARNINGS

#### FOR ALL TOOLS-

1. **Keep Guards in Place** and in working order.
2. **Remove Adjusting Keys and Wrenches** from tool before turning it on.
3. **Keep Work Area Clean.** Cluttered areas and benches invite accidents.
4. **Avoid Dangerous Environment.** Don't use power tools in damp or wet locations. Keep work area well lit. Don't expose power tools to rain.
5. **If you must use an electric tool in a damp or wet location;** make sure it is plugged into a circuit which is protected by a ground fault interrupt.
6. **Keep Children Away. ALL VISITORS SHOULD BE KEPT A SAFE DISTANCE FROM WORK AREA.**
7. **Store Idle Tools** in dry, high, or locked-up place out of reach of children.
8. **Don't Force Tool.** It will do a better and safer job at the rate for which it is designed.
9. **Use Right Tool.** Don't force a small tool or attachment to do the job of a heavy-duty tool.
10. **Wear Proper Apparel.** No loose clothing or jewelry to get caught in moving parts. Rubber gloves and footwear are recommended when working outdoors.
11. **Use Safety Glasses.**
12. **Don't Abuse Cord.** Never carry tool by cord or yank it to disconnect from receptacle. Keep cord from heat, oil, and sharp edges.
13. **Secure Work.** Use clamps or vise to hold work when practical. It's safer than using your hand and it frees both hands to operate tool.
14. **Don't Overreach.** Keep proper footing and balance at all times.
15. **Maintain Tools Properly.** Keep tools sharp and clean for best and safest performance. Follow instructions for lubricating and changing accessories. Equipment operators must have proper maintenance & instruction sheets. Be sure the tool operator reads and understands this information. If you don't have current maintenance and instruction sheets, contact the factory & we will supply them at no charge.
16. **Disconnect Tools** when not in use; before servicing; when changing accessories such as dies, cutters, etc.
17. **Avoid Accidental Starting.** Don't carry plugged-in tool with finger on switch. Be sure switch is off when plugging in.
18. **Outdoor Use Extension Cords.** When tool is used outdoors, use only extension cords suitable for use outdoors and so marked.
19. **Wear Ear Protection** if exposed to long periods of very noisy shop operations.
20. **Do not operate tools** while under the influence of alcohol, drugs or medication.

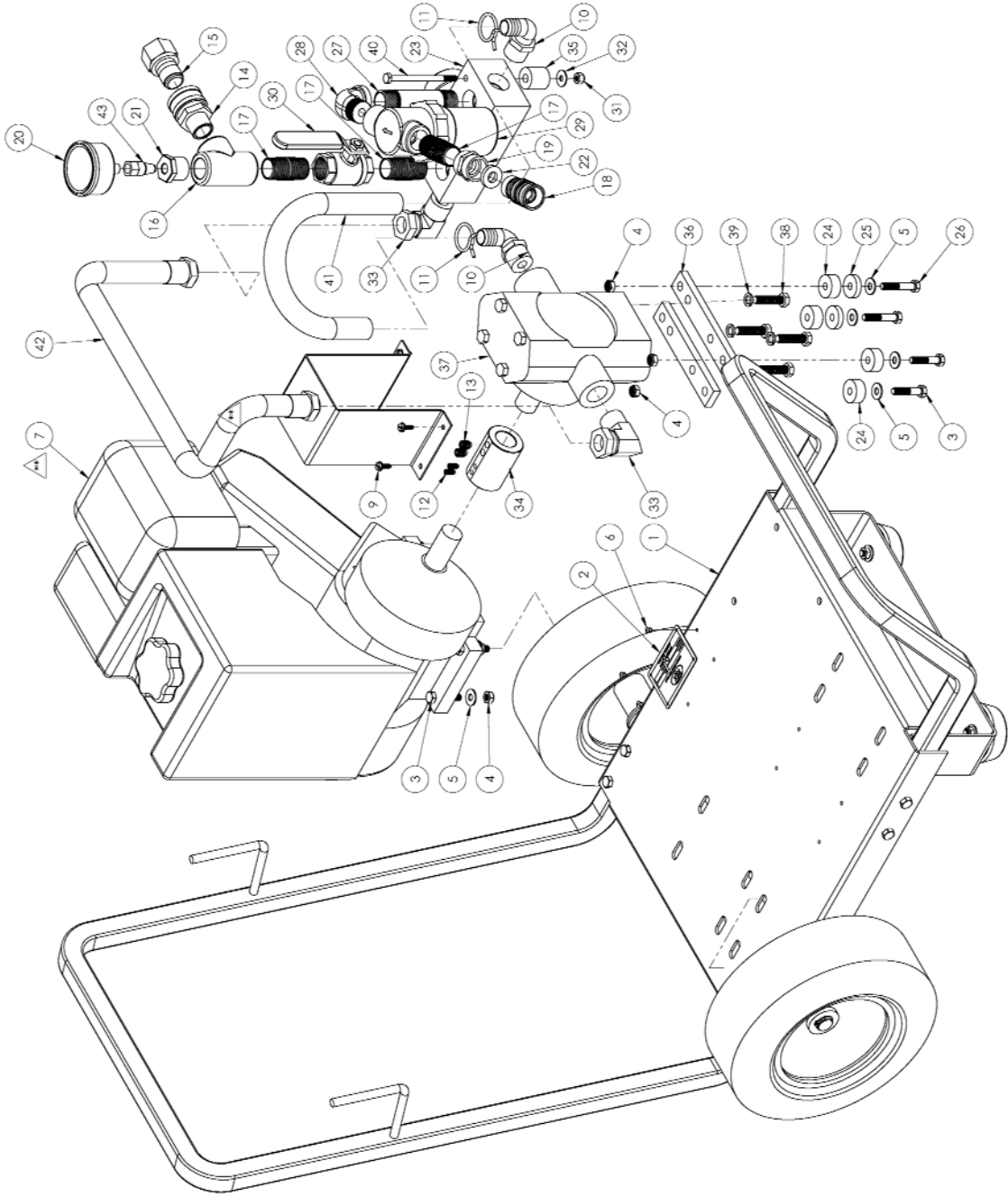

▲▲ USE PART #27.6095 (HONDA ENGINE) FOR PUMP ASSEMBLY #464530

<b>46453 / 464530 Pump</b>			
<b>Item</b>	<b>Part No</b>	<b>Description</b>	<b>Qty</b>
1	700136	PUMP CART	1
2	220874	NAME PLATE	1
3	275638	5/16 X 1-1/2" HEX HEAD CAP SCREW	6
4	275857	5/16-18 HEX NYLON INSERT LOCKNUT	8
5	275685	5/16" FLAT WASHER	8
6	275543	POP RIVET, STAR 4-2AAD	4
7	36326	6.5HP BRIGGS & STRATTON ENGINE	1
8	221306	COUPLING GUARD	1
9	275427	#10-24 X 5/8" SLTD HX WSHR, HD TYPE F	4
10	276116	3/4 MP X 3/4 MH 90 DEGREE HOSE BARB	2
11	276105	HOSE CLAMP, 1-1/8" OD RC HC-18S	2
12	276118	1/4-20 X 1/2" FULL DOG SET SCREW	2
13	276119	3/8-16 X 1/2" FULL DOG SET SCREW	2
14	276100	PH QD FEM HALF BST-6M	1
15	276101	PH QD MALE HALF BST N6	1
16	275644	3/4" TEE	1
17	276102	3/4" BRASS CLOSE NIPPLE	3
18	276099	3/4" HOSE QUICK DISCONNECT	1
19	275874	3/4" FH X 3/4" FP ADAPTER	1
20	36359	GAUGE, 0-600psi	1
21	276108	3/4" X 1/4" BRASS REDUCER BUSHING	1
22	275941	HOSE WASHER	1
23	700884	MANIFOLD AND UNLOADER ASSEMBLY	1
24	700126	SHOCK	4
25	700127	URETHANE WASHER	2
26	275639	5/16-18 X 1-3/4" HHCS	2
27	276113	3/4" X 4" NIPPLE	1
28	275643	3/4" STREET ELBOW	1
29	275933	STRAINER ASSEMBLY	1
30	275636	3/4" BALL VALVE	1
31	275426	1/4-20 ESNA STOP NUT	2
32	276540	1/4" FLAT WASHER	2
33	276123	HYD 90 ELL 3/4 NPT X 3/4	2
34	700120	PISTON PUMP COLLAR	1
35	700892	SPACER	2
36	700119	PISTON PUMP BASE	2
37	275808	PISTON PUMP	1
38	276122	3/8-16 X 1-1/2" HEX HEAD CAP SCREW	4
39	7179	3/8" SPLIT LOCK WASHER	4
40	276686	1/4-20 X 3-3/4" HEX HEAD CAP SCREW	2
41	700154	LOW PRESSURE HOSE	1
42	700125	HIGH PRESSURE HOSE	1
43	275860	PULSATION DAMPENER	1
44	222000	WARNING TAG *NOT SHOWN*	1
45	34550	SUCTION HOSE *NOT SHOWN*	1
46	221065	HIGH PRESSURE HOSE *NOT SHOWN*	1



Wheeler Rex ▪ 3744 Jefferson Road ▪ Ashtabula, Ohio 44005  
Tel: 800-321-7950 or 440-998-2788 ▪ Fax: 440-992-2925  
wheeler@wheelerrex.com ▪ www.wheelerrex.com